

### Product Warranty

Missile Works Corporation has exercised reasonable care in the design and manufacture of this product and warrants the original purchaser that the RRC<sup>2</sup> Rocket Recovery Controller is free of defects and that will operate at a satisfactory level of performance for a period of one year from the original date of purchase. If the system fails to operate as specified, then return the unit (or units) within the warranty period for repair or replacement (at our discretion). The system must be returned by the original purchaser, and be free of modification or any other physical damage which renders the system inoperable. Upon repair or replacement of the unit, Missile Works Corporation will return the unit postage paid, to the original purchaser.

### Product Disclaimer and Limit of Liability

Because the use and application of this equipment are beyond our control, the purchaser or user agrees to hold harmless Missile Works Corporation and their agents from any and all claims, demands, actions, debts, liabilities, judgements, costs, and attorney fees arising out of, claimed on account of, or in any manner predicated upon loss or damage to property of, or injuries to or the death of any and all persons arising out of the use this equipment. Due to the nature of electronic devices, the application and environments for those devices, the possibility of failure can never be totally ruled out. It is the responsibility of the purchaser or user of this equipment to properly test and simulate the actual conditions under which the device is intended to be used to ensure the highest degree of reliability and success.

Missile Works Corporation  
PO Box 1725  
Lyons, CO. 80540

Tel: 303.823.9222 / Fax: 303.823.9777  
On the World Wide Web @ [www.missileworks.com](http://www.missileworks.com)  
Copyright 2000-2007 by Missile Works Corporation.  
All rights reserved.



## User Manual and Instructions Model RRC2- mini - Rocket Recovery Controller Revision 1.1 (beta)

### System Overview

The RRC2-mini Rocket Recovery Controller provides two stage barometrically controlled deployment of rocket recovery systems and equipment. Two-stage (or dual) deployment is preferable to single parachute or streamer recovery systems for high-power rocketry. Recovery of large, heavy rockets with a small parachute or streamer alone does not supply enough drag to safely recover the rocket without damage. An adequately sized parachute deployed at a high altitude may cause the rocket to drift out of the launch area, making recovery difficult if not impossible.

Two stage (or dual) deployment recovery systems either separate the rocket airframe into two sections or eject a small drogue parachute or streamer at apogee, allowing the rocket to descend at a rapid yet controlled rate. When the rocket descends to a predetermined altitude above its initial launch elevation, it then deploys the main parachute, allowing the rocket to make a safe landing.

### General Specifications

Operational range	0-40K MSL	Dimensions	1" W x 3.15" L
Arming mode	barometric	Nominal Battery load	6-14ma
Minimum altitude for arming	250 ft. AGL	Output current (sinking)	5A @ 1 sec
Battery/Power range	9V / 7-10V	Continuity current	9µa

### Handling Precautions

- Always handle in a properly grounded environment. ESD damage is not covered under your warranty.
- Never touch/handle the unit when it is armed and connected to live pyrotechnic charges.
- Always allow the unit to adjust to ambient temperature conditions prior to arming and flying.
- Avoid exposure of an armed unit to direct sunlight, light level changes, heat, cold, or wind.
- Always prepare your rocket and recovery system components with the unit powered off.
- Never cycle the altimeter power switch off, then immediately back on (allow at least 10 seconds).

### Operational Overview

Figure 1 depicts the general component layout of the RRC2-mini Rocket Recovery Controller.

Figure 1 - General component layout of the RRC2-mini

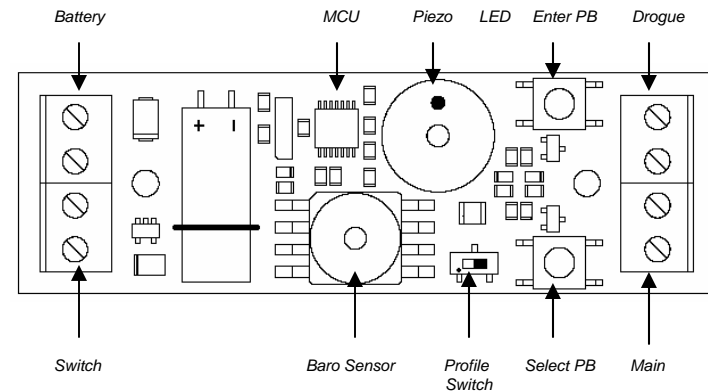

All user wiring connections are made to the compression terminals as shown. These terminals include: *Battery* (for an external 9V), *Switch* (for an external power switch), and *Drogue/Main* (for external deployment charges or controls).

Setup and Programming is facilitated by the *Enter/Select* pushbuttons in conjunction with the LED, and the user can choose between 2 complete setpoint profiles based on the power-up position of the *Profile Switch*.

More information on wiring and programming operations is provided in later sections of this document.

### Modes of Operation

The RRC2-mini has several distinct modes throughout the course of its normal operation. These modes of operation are easily identified by the function of the piezo and the LED.

#### Power-up mode with Battery Indicator

When power is first applied to the unit, it will provide a continuous 3-second chirp to indicate it has been switched on. During this 3-second chirp the LED will flicker in 1 of 3 colors relative to battery voltage. This indicator is a quick means of verifying the operational voltage of your battery without using a voltmeter. The LED colors and the associated battery voltages are:

GREEN	Battery Voltage 8.5 volts or above
YELLOW	Battery Voltage between 8.5 volts and 7.5 volts
RED	Battery Voltage below 7.5 volts

In addition, the unit has an optional battery voltage "lockout" feature during this mode. When enabled, this lockout feature activates a continuous alarm tone on the piezo and prevents further operation when the battery voltage is at or below 6.5 volts (refer to the Operations Mode setpoint option).

#### Baro initialization mode

After the Power-up mode, the unit goes through a 15-second baro initialization start-up delay. The LED will flash slowly in YELLOW slowly while in this mode. This delay period allows stabilization of the electronics and establishes an initial barometric history.

#### Battery/Setpoint Chirp Mode

The RRC2-mini has (2) optional start-up "chirping" options for an "on-the-pad" sanity check. The first of these options is the "Battery Voltage" chirp feature. When enabled, the battery voltage is chirped on the piezo (and flashed in YELLOW) in volts and tenths of a volt. The second option is the "All Setpoints" chirp feature. When enabled, ALL current setpoint values are chirped on the piezo (and flashed in YELLOW) in setpoint order (refer to the Operations Mode setpoint). If neither of these options are enabled, this mode is not executed and skipped altogether.

#### Launch Detect mode

When all previous modes are complete, the unit transitions into launch detect mode. The piezo and the GREEN LED indicate the continuity status of the drogue and main output terminals every 2 seconds as follows:

Long Beep/Flash	No continuity on Drogue or Main
1 Short Beep	Continuity on Drogue only
2 Short Beeps	Continuity on Main only
3 Short Beeps	Continuity on Drogue and Main

The unit also monitors the barometric sensor for a change of 250 feet in elevation to determine the launch of the rocket. After this change, the unit transitions into mach inhibit mode (if enabled) or apogee detection mode.

#### Mach Inhibit mode

When enabled after launch detection, the LED flashes RED at 1Hz. The unit is actively sampling baro changes, yet it will not apply the apogee detection algorithm during this delay mode. Mach Inhibit mode is used to prevent the barometric "spoofing" that occurs during sonic-subsonic transitions during rocket boost. This is a Bernoulli-based effect, and is most pronounced at motor burnout (typically the largest velocity delta of the rocket flight). After the expiration of the mach delay, the unit transitions into apogee detection mode.

#### Apogee Detection Mode

When the unit is actively sampling for the apogee event, the LED will be SOLID RED. When the unit determines that apogee has occurred (by a positive pressure slope), it will initiate the apogee event. The Drogue and Main outputs may activate based upon the configuration of the Deployment Mode setpoint and the Drogue/Main Delay setpoints. (note: All flight data is written to non-volatile memory immediately after the apogee event).

#### Main Detection Mode

After the unit has detected apogee, it will transition to Main Detection Mode, indicated by a SOLID YELLOW LED. The unit will continue to sample barometric pressure during the descent phase of the flight until it reaches the designated main deployment elevation (above ground). The Drogue and Main outputs may activate based upon the configuration of the Deployment Mode setpoint and the Drogue/Main Delay setpoints.

#### Report mode

After detection of the main elevation, the unit will report the peak altitude it measured during flight. The piezo and the GREEN LED will continuously report the peak altitude by chirping out the individual digits of the measurement. Depending on the peak altitude, the unit will announce 3, 4, or 5 digits. For example, let's say the rocket flew to a peak altitude of 1230 feet. The unit would beep as follows:

Beep...pause...Beep, Beep...pause...Beep, Beep, Beep...pause...Beeeeeeeeeeeep... short buzz....(repeat)

#### Interactive Operation and Programming

The RRC2-mini is interactively programmed using the SELECT and ENTER pushbuttons in conjunction with the LED in a menu driven user interface. User programmable setpoints, historical flight data, and diagnostics are all accessible via this interactive operation. Please refer to the Setpoint and Operations Matrix reference included with this manual. (note: a brief chirp acknowledges any button press).

#### Accessing the Start Menu

To start the interactive operation of the RRC2-mini, press & hold the SELECT pushbutton while applying power to the unit. Release the pushbutton after you hear a brief chirp from the piezo. You're now at the Start Menu and displaying the first choice (SLOW FLASHING RED / Setpoint Menu)

#### Start Menu Navigation

To scroll to the next available choice in the menu, tap the SELECT pushbutton. To make a choice in this menu, tap the ENTER pushbutton. (note: a brief chirp acknowledges your button press).

**IMPORTANT:** Inadequate sealing of the electronics bay, or exposure of the electronics to ejection charge heat, BP residue, or pressure will cause the RRC<sup>2</sup> to malfunction.

**IMPORTANT:** Black Powder residue is extremely corrosive to the circuit board and its components. Always clean off any inadvertent residue immediately to avoid long term damage to the unit.

#### Static Pressure Ports

Equally as important as sealing the electronics bay or payload section is the proper location, sizing, quality, and quantity of static pressure ports. Always try to locate a static port on the airframe where it is not obstructed by any object that may cause turbulence upstream of the airflow over the port. Also try to locate the static port as far away as possible from the nose cone or body transition sections. The rule of thumb is a 1/4" diameter hole for every 100 cubic inches of bay volume.

#### Bay Volume Calculations

The first step to sizing of the static port hole is to compute volume... use the following formula:

$$\text{Volume (cubic inches)} = \text{Bay Radius (inches)} \times \text{Bay Radius (inches)} \times \text{Bay Length (inches)} \times 3.14$$

With the known volume of the electronics bay or payload section, calculate the required nominal diameter for a single static port with the appropriate formula:

If volume <= 100 cubic inches, you can use this simple approximation for a vent hole:

$$\text{Single Port Diameter (inches)} = \text{Volume} / 400$$

If volume > 100 cubic inches, use this formula to calculate vent hole diameter(s):

$$\text{Single Vent Diameter} = 2 * \text{SQRT} ( \text{Volume} * 0.0004908 / 3.14 )$$

$$\text{Single Vent Area} = ( \text{Single Vent Diameter} / 2 ) * ( \text{Single Vent Diameter} / 2 ) * 3.14$$

$$\text{Multi Vent Diameter} = 2 * \text{SQRT} ( ( \text{Single Vent Area} / \# \text{ of holes} ) / 3.14 )$$

#### Physical Mounting Dimensions

Figure 3 depicts the physical mounting requirements for the RRC2-mini. 4/40 screw hardware is recommended to mount the unit into the payload section of the rocket or through a rocket airframe. Nylon standoffs or insulated neoprene washer are also recommended for mounting against a hard back plate.

Figure 3- Mounting Dimensions for the RRC2-mini

